

Why Vaillant?

Because quality accessories create the perfect solution.



Contents

uniSTOR cylinder range for heat pumps	4
Cylinder compatibility matrix chart	5
uniSTOR pre-plumbed cylinder	6
uniSTOR pre-plumbed slimline cylinder	10
uniSTOR standard cylinder	14
uniSTOR large capacity cylinder	18
auroSTOR large capacity cylinder	22
uniSTOR and auroSTOR accessories	26
Pressure drop chart	27



Why Vaillant?



The uniSTOR heat pump cylinder range has been designed to work in harmony with Vaillant heat pumps, to provide highly efficient heating and hot water systems.

uniSTOR's large surface area and smooth coil design maximises heat transfer, to ensure connected Vaillant heat pumps run at their optimum efficiency, to reduce running costs and increase hot water performance.

Ranging from 150 up to 800 litres, our uniSTOR heat pump cylinders are available in both pre-plumbed (150-300 litres only) and standard options, giving you and your customers even more flexibility. In addition to this, the 250 and 300 litre cylinders have an increased coil size making them compatible with a wider range of ground source heat pump systems.

uniSTOR cylinders also have a Global Warming Potential of less than 5 thanks to thermal injected insulation, as well as a 100% recyclable stainless steel tank with an ultra-hard-wearing outer shell, to deliver a highly efficient and sustainable heating system.

Choosing your perfect solution

Cylinder compatibility matrix chart

The following cylinder compatibility matrix is provided to help guide you during the specification stages of a renewable heat pump system. Vaillant cylinders provide excellent efficiency, durability and ensure optimum system performance when combined with Vaillant heat pumps. For further information and support, please speak to one of our technical advisors on 0330 100 3540.

aroTHERM air-to-water heat pumps

	aroTHERM	uniSTOR 150 litre cylinder	uniSTOR 200 litre cylinder	uniSTOR 250 litre cylinder	uniSTOR 300 litre cylinder	uniSTOR 500 litre cylinder	auroSTOR 500 litre cylinder*	uniSTOR 800 litre cylinder
	5kW	✓	✓					
	8kW	✓	✓	✓	✓			
	11kW	✓	✓	✓	✓	✓	✓	
	15kW		✓	✓	✓	✓	✓	✓

flexoTHERM ground source heat pumps

	flexoTHERM	uniSTOR 150 litre cylinder	uniSTOR 200 litre cylinder	uniSTOR 250 litre cylinder	uniSTOR 300 litre cylinder	uniSTOR 500 litre cylinder	auroSTOR 500 litre cylinder*	uniSTOR 800 litre cylinder
	5kW	✓	✓	✓				
	8kW		✓	✓	✓		✓	
	11kW			✓	✓	✓	✓	
	15kW			✓	✓	✓		✓
	19kW					✓		✓

* auroSTOR 500 litre cylinder for combined heat pump and solar thermal systems

geoTHERM ground source heat pumps

	geoTHERM	uniSTOR 500 litre cylinder	uniSTOR 800 litre cylinder
	22kW	✓	✓
	30kW		✓
	38kW		✓
	46kW	see note below	

NOTE: For advice on cylinders that are compatible with geoTHERM 46kW, please contact our technical department.

Pre-plumbed

uniSTOR.



The pre-plumbed uniSTOR heat pump cylinder range comes in 200, 250 and 300 litre capacity. The pre-plumbed range is designed to simplify installation and comes with inline connections and a mounting plate for controls, all sized to accommodate the heat pump interface.

Key features and benefits

- **Includes 28mm three-way valve**
Allows cost saving by reducing number of valves
- **Supplied with expansion vessel and sensor**
To provide a complete system solution
- **Concealed cable duct**
Improves aesthetics of wiring from the cylinder and controls
- **Thermodynamically positioned sensor pocket**
Optimises system performance
- **Large diameter, smooth coil technology**
Provides quiet operation, reduces build-up of scale and aids in long term efficiency through automatic descaling
- **Advanced technology using thermal injected polyurethane insulation**
Superior insulation and efficiency
- **Global Warming Potential less than 5 and ozone depletion of 0**
Designed around environmental requirements
- **Factory fitted immersion heater**
Emergency backup in case of main heat source failure
- **Automatic air vent included**
Simplifies installation
- **Adjustable feet**
Makes on-site installation easier

Pre-plumbed uniSTOR technical specification

Technical data	Unit	200 litre pre-plumbed uniSTOR	250 litre pre-plumbed uniSTOR	300 litre pre-plumbed uniSTOR
Article number		0020237130	0020237131	0020237132
Total tank capacity	l	198.4	249.2	288.7
Actual capacity (without coil volume)	l	190.7	236.3	273.5
Hot water capacity / draw off*	l	172.5	211.0	230.9
Standby losses	kWh/24h	1.2	1.4	1.6
Energy-related Products	band	B	B	B
Heat exchanger volume	l	7.7	12.9	15.2
Heat exchanger surface	m ²	1.4	2.4	2.8
Primary flow rate	l/h	900	900	900
Heat exchanger pressure drop	mbar	100	170	200
Maximum operating DHW temperature	°C	85	85	85
Maximum operating heat circuit temperature	°C	95	95	95
Quantity of temperature sensor tubes	qty	1	1	1
Size of supplied expansion vessel	l	18	25	25
Immersion heater rating	kW	3.0	3.0	3.0
Immersion heater cable size	mm	1.5	1.5	1.5
Immersion heater current	A	13	13	13

* Calculation from test EN 12897

Dimensions	Unit	200 litre pre-plumbed uniSTOR	250 litre pre-plumbed uniSTOR	300 litre pre-plumbed uniSTOR
Outer diameter with insulation	mm	595	595	595
Height with insulation	mm	1265	1535	1745
Net weight empty cylinder	kg	58.0	73.3	80.6
Weight of filled cylinder	kg	249.4	313.6	369.4
Insulation thickness	mm	50	50	50

Connections	Unit	200 litre pre-plumbed uniSTOR	250 litre pre-plumbed uniSTOR	300 litre pre-plumbed uniSTOR
Primary heat exchanger flow and return connections	BSP female	¾"	¾"	¾"
Cold and hot water connections	BSP female	¾"	¾"	¾"
Temperature sensor sleeve diameter	mm	8	8	8
Immersion heater boss diameter	BSP female	1 ¼"	1 ¼"	1 ¼"

Pre-plumbed uniSTOR

Dimensions

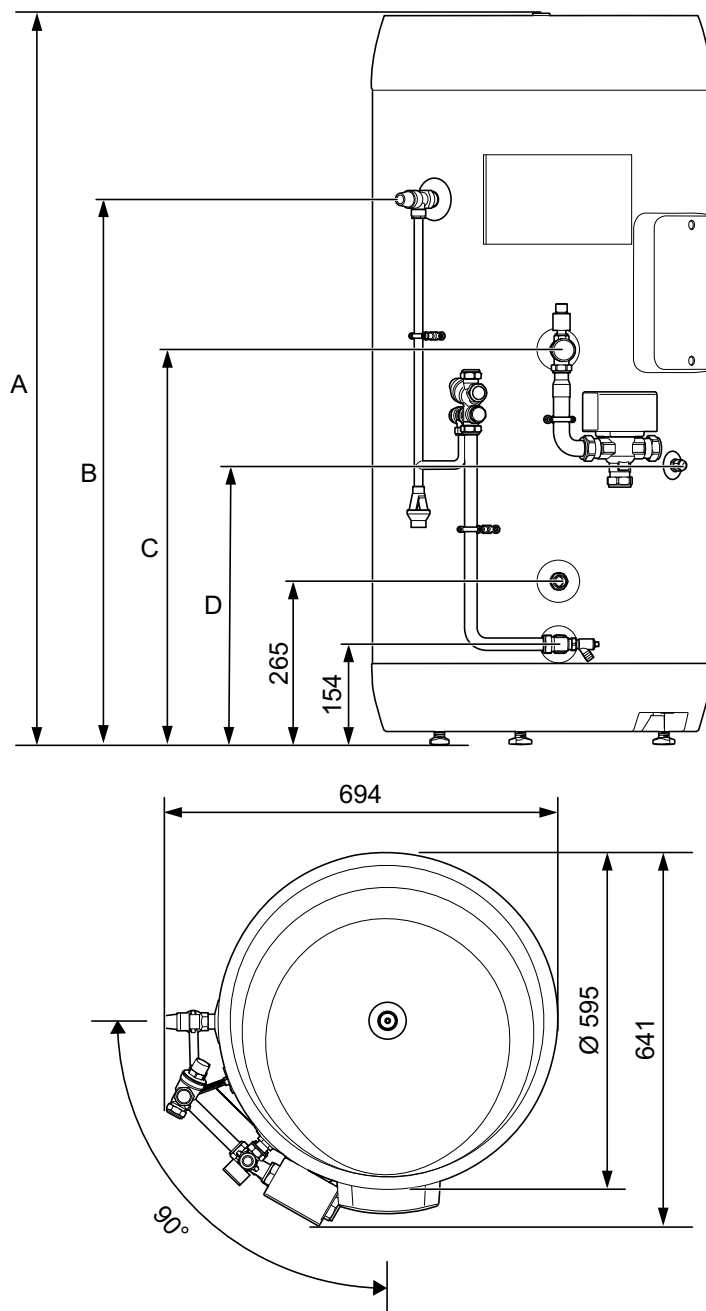

Heat pump cylinder	Unit	A	B	C	D
200 litre pre-plumbed uniSTOR	mm	1,265	940	675	470
250 litre pre-plumbed uniSTOR		1,535	1,210	865	565
300 litre pre-plumbed uniSTOR		1,745	1,420	865	565

Connections

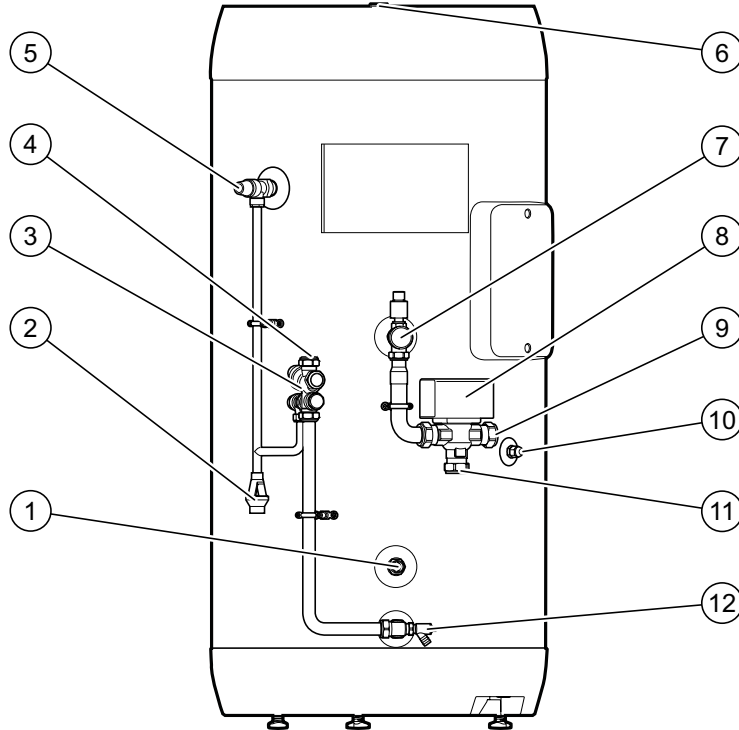

Item	Description
1	Cylinder heating return
2	Tundish
3	Unvented cylinder kit
4	Cold water inlet
5	Temperature and pressure expansion relief valve
6	Hot water outlet
7	Cylinder heating inlet
8	Three-way motorised valve
9	Heating circuit heating flow
10	Cylinder dry pocket for sensor
11	Heating flow from the heat pump
12	Drain valve

NOTE: Items included with pre-plumbed uniSTOR cylinders are documentation and expansion vessel. Tundish, three-way motorised valve and unvented cylinder kit are pre-installed on the cylinder.

Pre-plumbed

slimline uniSTOR.



The pre-plumbed slimline uniSTOR cylinder has been designed with the installer in mind: a smaller design for space sensitive installations, as well as improving installation times. The cylinder has had a specifically designed smooth coil, which is purposefully placed to ensure optimum heat transfer within the compact cylinder. The slimline cylinder still offers high performance with a low standby loss of 1.8kW per 24 hours ensuring the hot water stays hot all day long.

Key features and benefits

■ 28mm three-way valve supplied

Allows cost saving by reducing number of valves

■ Expansion vessel and sensor included with product

Complete system solution offering

■ Concealed cable duct

Improves aesthetics of wiring from the cylinder and controls

■ Thermodynamically positioned sensor pocket

Optimises system performance

■ Large diameter, smooth coil technology

Provides quiet operation, reduces build-up of scale and aids in long term efficiency through automatic descaling

■ Advanced technology using thermal injected polyurethane insulation

Superior insulation and efficiency

■ Global Warming Potential less than 5 and ozone depletion of 0

Designed around environmental requirements

■ Factory fitted immersion heater

Emergency backup in case of main heat source failure

■ Automatic air vent included

Simplifies installation

Pre-plumbed slimline uniSTOR technical specification

Technical data	Unit	150 litre pre-plumbed slimline uniSTOR
Article number		0020237129
Total tank capacity	l	145.1
Actual capacity (without coil volume)	l	139.5
Hot water capacity / draw off*	l	127.0
Standby losses	kWh/24h	1.8
Energy-related Products	band	C
Heat exchanger volume	l	5.6
Heat exchanger surface	m ²	1.0
Primary flow rate	l/h	900
Heat exchanger pressure drop	mbar	70
Maximum operating DHW temperature	°C	85
Maximum operating heat circuit temperature	°C	95
Quantity of temperature sensor tubes	qty	1
Size of supplied expansion vessel	l	12
Immersion heater rating	kW	3.0
Immersion heater cable size	mm	1.5
Immersion heater current	A	13

* Calculation from test EN 12897

Dimensions	Unit	150 litre pre-plumbed slimline uniSTOR
Outer diameter with insulation	mm	435
Height with insulation	mm	1642
Net weight empty cylinder	kg	54.5
Weight of filled cylinder	kg	193.9
Insulation thickness	mm	40

Connections	Unit	150 litre pre-plumbed slimline uniSTOR
Primary heat exchanger flow and return connections	BSP female	¾"
Cold and hot water connections	BSP female	¾"
Temperature sensor sleeve diameter	mm	8
Immersion heater boss diameter	BSP female	1"

Pre-plumbed slimline uniSTOR

Dimensions

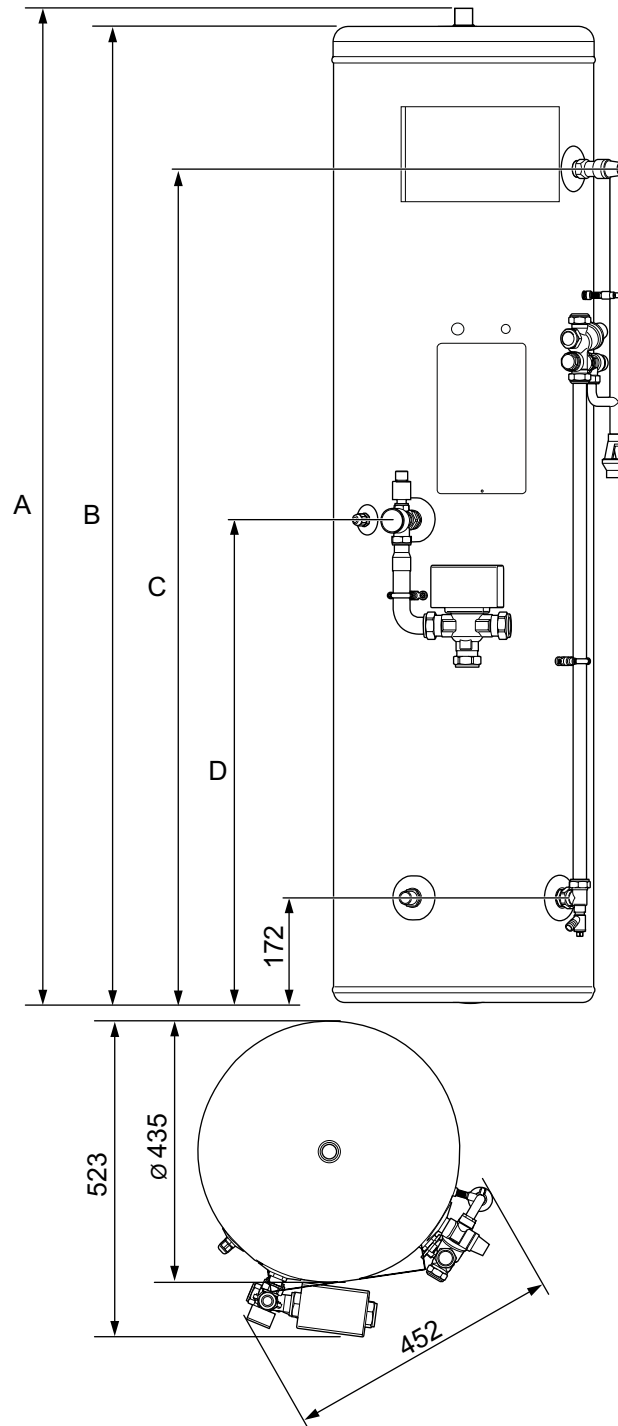

Heat pump cylinder	Unit	A	B	C	D
150 litre pre-plumbed slimline uniSTOR	mm	1,642	1,613	1,377	797

Connections

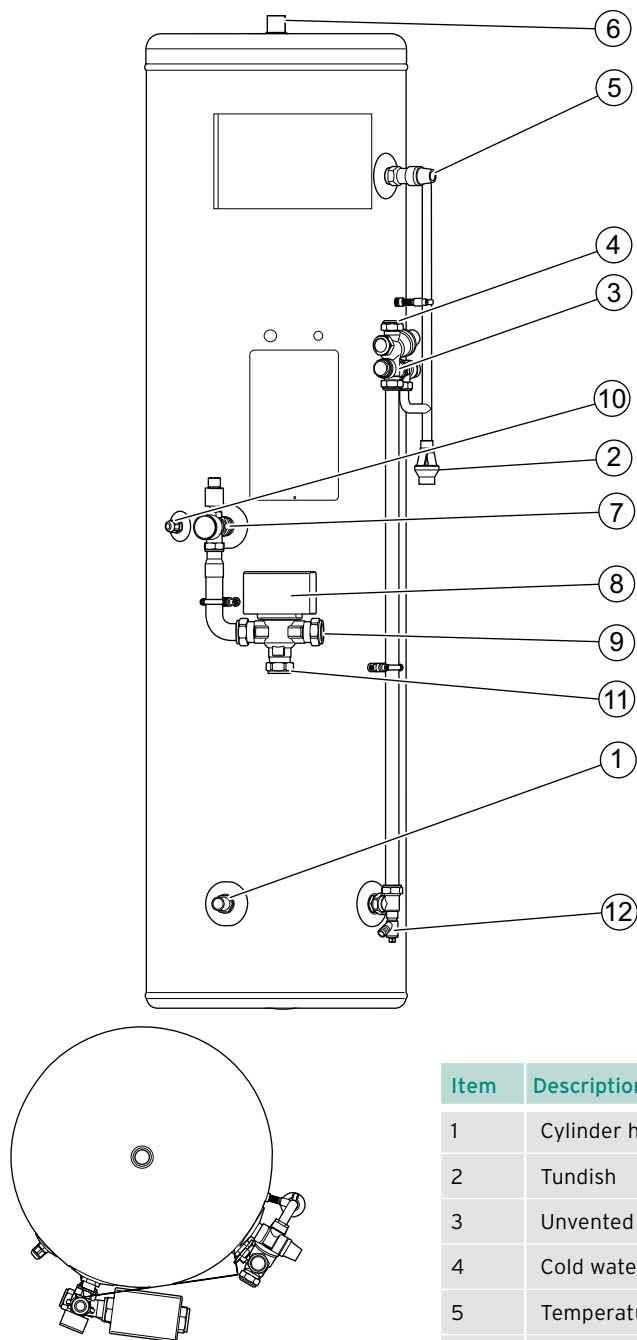

Item	Description
1	Cylinder heating return
2	Tundish
3	Unvented cylinder kit
4	Cold water inlet
5	Temperature and pressure expansion relief valve
6	Hot water outlet
7	Cylinder heating inlet
8	Three-way motorised valve
9	Heating circuit heating flow
10	Cylinder dry pocket for sensor
11	Heating flow from heat pump
12	Drain valve

NOTE: Items included with pre-plumbed uniSTOR cylinders are documentation and expansion vessel. Tundish, three-way motorised valve and unvented cylinder kit are pre-installed on the cylinder.

Standard

uniSTOR.



The standard uniSTOR heat pump cylinder is available in 150, 200, 250 and 300 litres. Each cylinder uses the latest thermal injected insulation for the lowest heat losses in its class, with as little as 1kW per 24 hours. The strategically positioned large diameter, smooth coil provides optimum hot water performance and automatically de-scales to ensure long term efficient hot water generation.

Key features and benefits

■ **Heat loss from as low as 1kW/24 hours**

Reduce energy bills for end users

■ **Thermal injected polyurethane insulation combined with vacuum panels**

Superior insulation and efficiency

■ **Slim design**

Fits into compact spaces allowing for flexible siting

■ **28mm three-way valve supplied**

Reduced cost of installation guarantee

■ **Expansion vessel and sensor included**

Complete system solution offering

■ **Concealed cable duct**

Improves aesthetics of wiring from the cylinder and controls

■ **Thermodynamically positioned sensor pocket**

Optimises system performance

■ **Large diameter, smooth coil technology**

Provides quiet operation, reduces build-up of scale and aids in long term efficiency through automatic descaling

■ **Advanced technology using thermal injected polyurethane insulation**

Superior insulation and efficiency

■ **Global Warming Potential less than 5 and ozone depletion of 0**

Designed around environmental requirements

■ **Factory fitted immersion**

Emergency backup in case of main heat source failure

■ **Adjustable feet**

Makes on-site installation easier

Standard uniSTOR technical specification

Technical data	Unit	150 litre standard uniSTOR	200 litre standard uniSTOR	250 litre standard uniSTOR	300 litre standard uniSTOR
Article number		0020235271	0020235272	0020235273	0020235274
Total tank capacity	l	148.6	198.4	249.2	288.7
Actual capacity (without coil volume)	l	143.8	190.7	236.3	273.5
Hot water capacity / draw off*	l	127.0	172.5	211.0	230.9
Standby losses	kWh/24h	1.0	1.2	1.4	1.6
Energy-related Products	band	B	B	B	B
Heat exchanger volume	l	5.5	7.7	12.9	15.2
Heat exchanger surface	m ²	1.0	1.4	2.4	2.8
Primary flow rate	l/h	900	900	900	900
Heat exchanger pressure drop	mbar	44	100	170	200
Maximum operating DHW temperature	°C	85	85	85	85
Maximum operating heat circuit temperature	°C	95	95	95	95
Quantity of temperature sensor tubes	qty	1	1	1	1
Size of supplied expansion vessel	l	12	18	25	25
Immersion heater rating	kW	3.0	3.0	3.0	3.0
Immersion heater cable size	mm	1.5	1.5	1.5	1.5
Immersion heater current	A	13	13	13	13

* Calculation from test EN 12897

Dimensions	Unit	150 litre standard uniSTOR	200 litre standard uniSTOR	250 litre standard uniSTOR	300 litre standard uniSTOR
Outer diameter with insulation	mm	595	595	595	595
Height with insulation	mm	975	1265	1535	1745
Net weight empty cylinder	kg	38.0	46.0	61.0	67.6
Weight of filled cylinder	kg	181.3	237.4	301.3	356.8
Insulation thickness	mm	50	50	50	50

Connections	Unit	150 litre standard uniSTOR	200 litre standard uniSTOR	250 litre standard uniSTOR	300 litre standard uniSTOR
Primary heat exchanger flow and return connections	BSP female	¾"	¾"	¾"	¾"
Cold and hot water connections	BSP female	¾"	¾"	¾"	¾"
Temperature sensor sleeve diameter	mm	8	8	8	8
Immersion heater boss diameter	BSP female	1 ¼"	1 ¼"	1 ¼"	1 ¼"

Standard uniSTOR

Dimensions

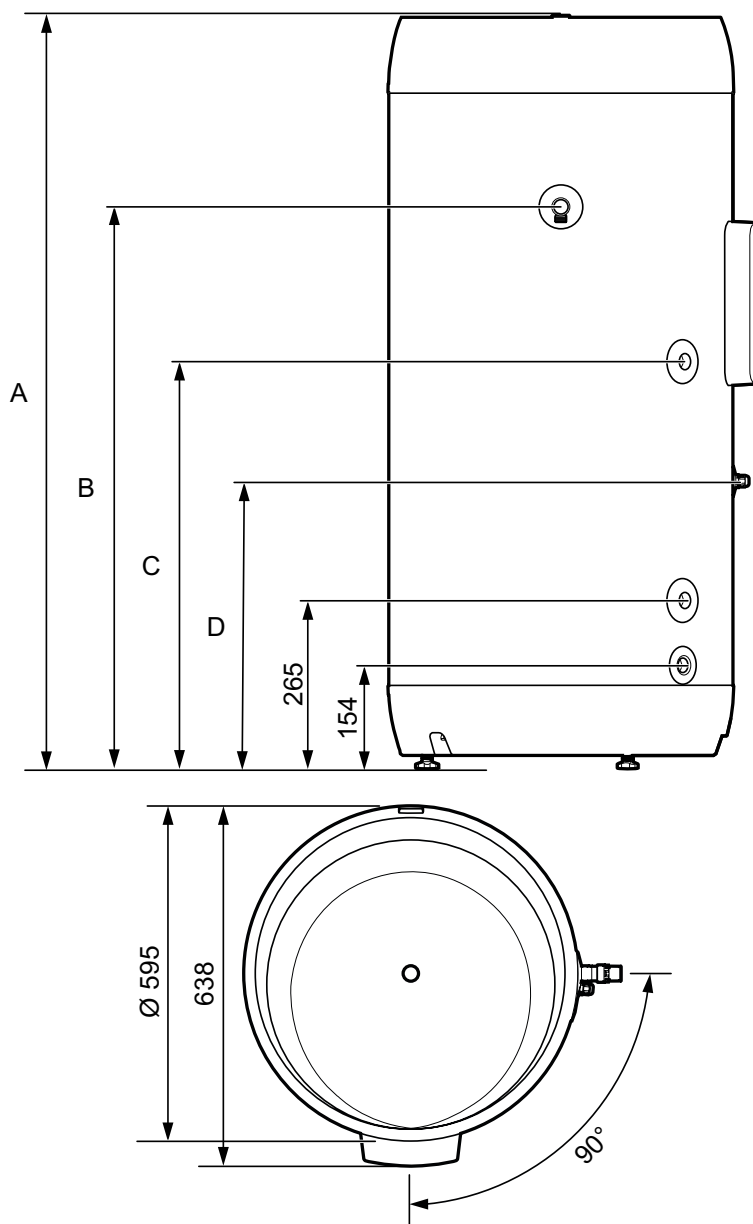

Heat pump cylinder	Unit	A	B	C	D
150 litre standard uniSTOR	mm	1,000	675	520	393
200 litre standard uniSTOR		1,265	940	675	470
250 litre standard uniSTOR		1,535	1,210	865	565
300 litre standard uniSTOR		1,745	1,420	865	565

Connections

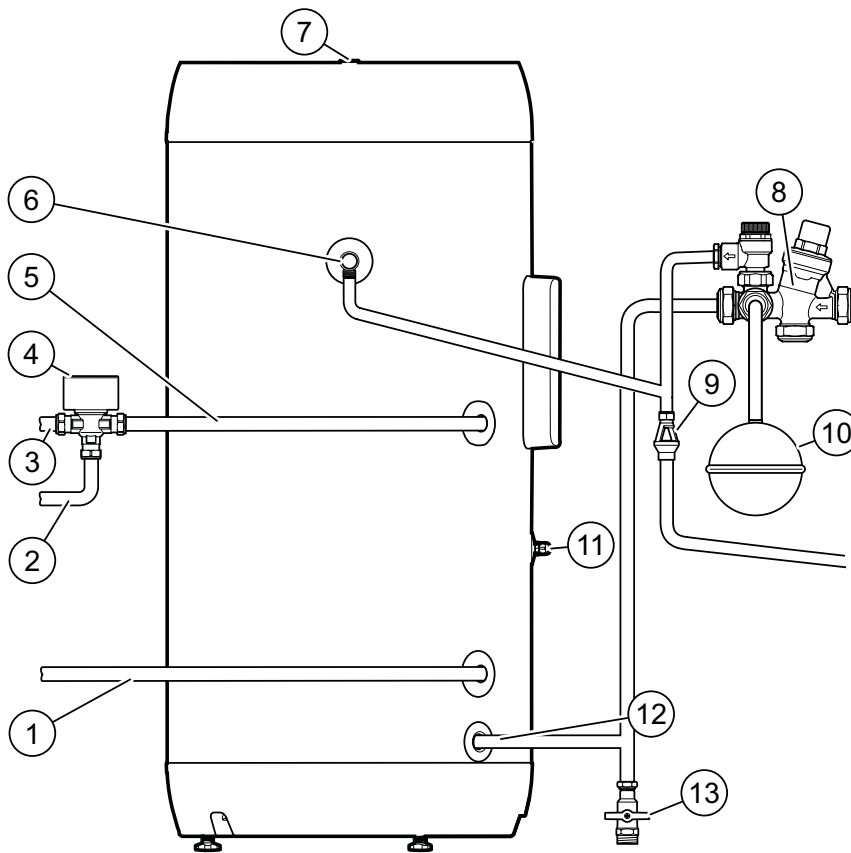

Item	Description
1	Heat pump return
2	Heating flow from heat pump
3	Heating circuit heating flow
4	Three-way motorised valve
5	Cylinder heating inlet
6	Temperature and pressure expansion relief valve
7	Hot water outlet
8	Unvented cylinder kit
9	Tundish
10	Expansion vessel
11	Cylinder dry pocket for sensor
12	Cold water inlet
13	Drain valve

NOTE: Items included with standard uniSTOR cylinders are documentation, tundish, three-way motorised valve, unvented cylinder kit, expansion vessel and 3/4" x 28mm MI-copper compression fittings. 250 and 300 litre standard uniSTOR comes with secondary return T piece connection.

Large capacity

uniSTOR.



The new Vaillant cylinder range includes two large capacity cylinders and a complete range of accessories. The 500 and 800 litre uniSTOR's have impressive coil sizes, of 4.7m² and 7m² which are manufactured using high grade stainless steel, and pass the highest Vaillant standards and quality control requirements.

In addition, a comprehensive range of accessories are available which includes a choice of unvented cylinder kits, compatible expansion vessels and a 7.5kW immersion (800 litre only). This provides the installer and specifier with maximum flexibility during design and installation.

Both cylinders can also be easily cascaded to generate higher requirements for hot water. Vaillant's dedicated commercial and technical designers can advise on any project for additional support and peace of mind.

Key features and benefits

■ Single guarantee for all components

Complete peace of mind from one manufacturer

■ Unvented cylinder kit, expansion vessel and sensor available as an accessory

Complete system solution offering whilst meeting all building regulations

■ Large diameter, smooth coil technology

Provides quiet operation, reduces build-up of scale and aids in long term efficiency through automatic descaling

■ Global Warming Potential less than 5 and ozone depletion of 0

Designed around environmental requirements

■ In-built lifting eye

Easy to move over any terrain

■ Secondary return

Accommodates complex and larger dwellings

■ Factory fitted T&P valve

Ensures safety requirements to meet regulations

■ Large 7.5kW single phase immersion available

Emergency backup in case of main heat source failure (800 litre only)

■ Inspection port included

Meets requirement of many commercial specifications (800 litre only)

Large capacity uniSTOR technical specification

Technical data	Unit	500 litre uniSTOR	800 litre uniSTOR
Article number		0010019228	0010019229
Total tank capacity	l	541.4	784.0
Actual capacity (without coil volume)	l	512.0	740.0
Hot water capacity / draw off*	l	460.0	635.0
Standby losses	kWh/24h	2.5	3.0
Energy-related Products	band	C	C
Heat exchanger volume	l	29.0	44.0
Heat exchanger surface	m ²	4.7	7.0
Primary flow rate	l/h	1800	1800
Maximum operating DHW temperature	°C	85	85
Maximum operating heat circuit temperature	°C	95	95
Quantity of temperature sensor tubes	qty	2	2
Size of expansion vessel	l	50 (supplied as an accessory)	80 (supplied as an accessory)
Immersion heater rating	kW	5.0	7.5
Immersion heater cable size	mm	4.0	6.0
Immersion heater current	A	32	40

* Calculation from test EN 12897

Dimensions	Unit	500 litre uniSTOR	800 litre uniSTOR
Outer diameter with insulation	mm	785	986
Height with insulation	mm	1.9	1.9
Net weight empty cylinder	kg	140	231
Weight of filled cylinder	kg	690	1015
Insulation thickness	mm	65	100

Connections	Unit	500 litre uniSTOR	800 litre uniSTOR
Primary heat exchanger flow and return connections	BSP female	1 ½"	1 ½"
Cold and hot water connections	BSP female	1 ½"	1 ½"
Temperature sensor sleeve diameter	mm	8	8
Immersion heater boss diameter	BSP female	1 ¼"	1 ¼"

Large capacity uniSTOR

Dimensions

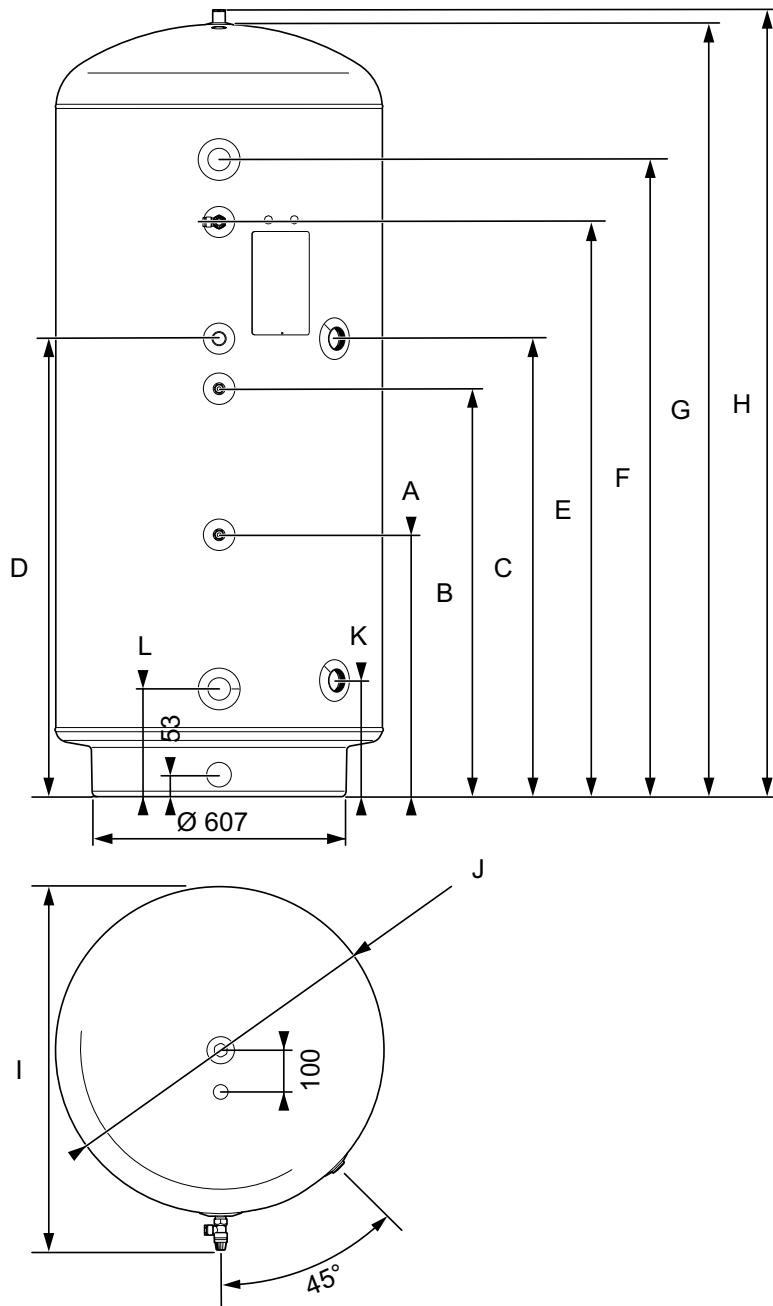

Heat pump cylinder	Unit	A	B	C	D	E	F	G	H	I	J	K	L
500 litre uniSTOR	mm	649	979	1,099	1,099	1,379	1,529	1,853	1,886	872	785	279	259
800 litre uniSTOR		745	1,180	1,130	1,280	1,381	1,480	1,872	1,905	1,071	986	310	310

Connections

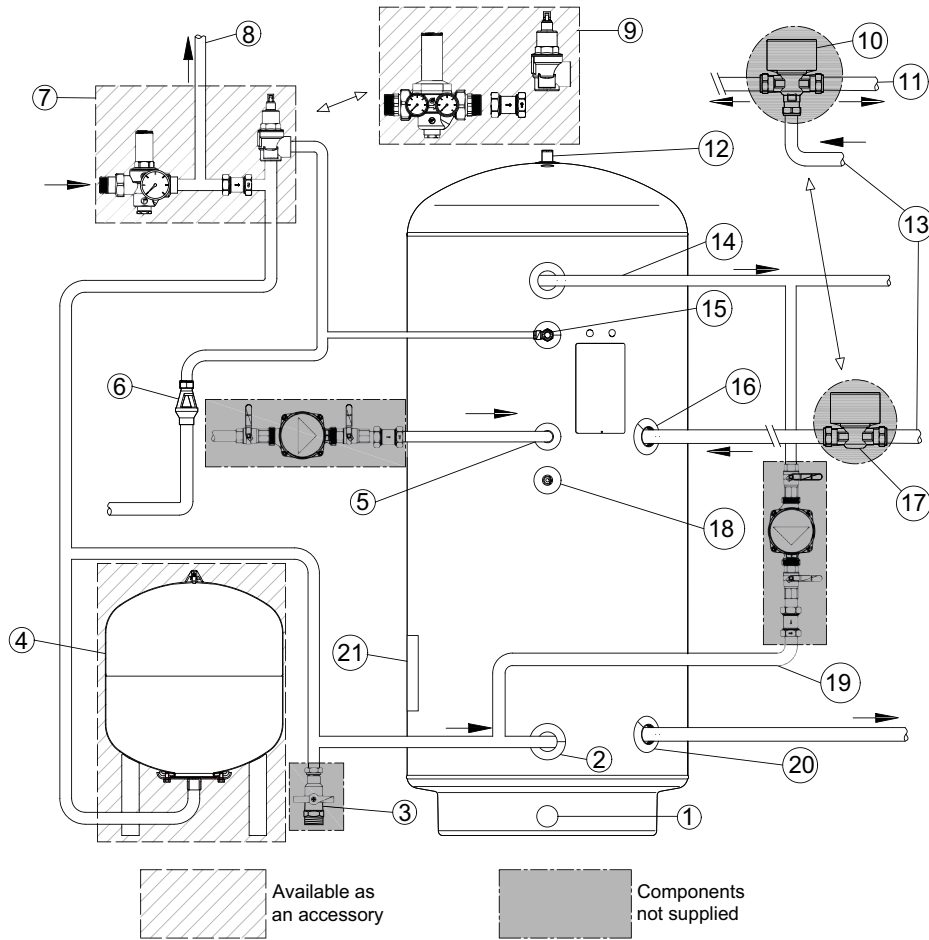

Item	Description
1	Cylinder drain
2	Cold water inlet
3	System drain valve (not supplied)
4	Expansion vessel
5	Secondary circulation (not supplied)
6	Tundish
7	Safety group (available as an accessory)
8	Balanced cold water
9	2" Safety group supplied with additional pressure gauge
10	Heat pump connection method: three-way motorised diverter valve (not supplied)
11	Heating circuit heating flow
12	Non-removable lifting eye (manual vent behind lifting eye)
13	Heating flow from heat source
14	Domestic hot water outlet
15	Temperature-pressure relief valve
16	Cylinder heating flow
17	Boiler connection method: motorised valve (not supplied)
18	Temperature sensor pocket
19	Legionella protection loop (not supplied)
20	Cylinder heating return
21	Inspection hatch (800 litre only)

NOTE: Items included with large capacity uniSTOR cylinders are documentation and tundish. Unvented cylinder kits and expansion vessels are available in a range of sizes as an accessory, see page 26.

Large capacity

auroSTOR.



The large capacity 500 litre twin coil auroSTOR cylinder has been specifically designed to accommodate both a heat pump and solar thermal system. The 500 litre twin coil auroSTOR cylinder utilises two smooth coils to ensure a quick heat recovery and prolonged life, due to its automatic de-scaling properties.

auroSTOR has a multitude of accessories to complete the Vaillant system including a choice of unvented cylinder kits and a compatible expansion vessel.

auroSTOR completes a Vaillant renewable system by enabling solar thermal options.

Key features and benefits

■ Single guarantee for all components

Complete peace of mind from one manufacturer

■ Unvented cylinder kit, expansion vessel and sensor available as an accessory

Complete system solution offering, whilst meeting all building regulations

■ Large diameter, smooth coil technology

Provides quiet operation, reduces build-up of scale and aids in long term efficiency through automatic descaling

■ Global Warming Potential less than 5 and ozone depletion of 0

Designed around environmental requirements

■ Secondary return

Accommodates complex and larger dwellings

■ Multiple sizes of unvented cylinder kit available

Accommodates all common pipes sizes

■ Factory fitted T&P valve

Ensures safety requirements to meet building regulations

■ Factory fitted immersion heater

Emergency backup in case of main heat source failure

Large capacity auroSTOR technical specification

Technical data	Unit	500 litre auroSTOR
Article number		0010019234
Total tank capacity	l	541.4
Actual capacity (without coil volume)	l	510.0
Hot water capacity / draw off*	l	248.0/438.0
Standby losses	kWh/24h	2.6
Energy-related Products	band	C
Heat exchanger volume	l	23.0 (upper) / 8.0 (lower)
Heat exchanger surface	m ²	2.3 (upper) / 1.0 (lower)
Primary flow rate	l/h	900
Maximum operating DHW temperature	°C	85
Maximum operating heat circuit temperature	°C	95
Quantity of temperature sensor tubes	qty	2
Size of expansion vessel	l	50 (supplied as an accessory)
Immersion heater rating	kW	5.0
Immersion heater cable size	mm	4.0
Immersion current	A	32

* Calculation from test EN 12897

Dimensions	Unit	500 litre auroSTOR
Outer diameter with insulation	mm	785
Height with insulation	mm	1.9
Net weight empty cylinder	kg	155
Weight of filled cylinder	kg	705
Insulation thickness	mm	65

Connections	Unit	500 litre auroSTOR
Primary heat exchanger flow and return connections	BSP female	1 ½"
Cold and hot water connections	BSP female	1 ½"
Temperature sensor sleeve diameter	mm	8
Immersion heater boss diameter	BSP female	1 ¼"

Large capacity auroSTOR

Dimensions

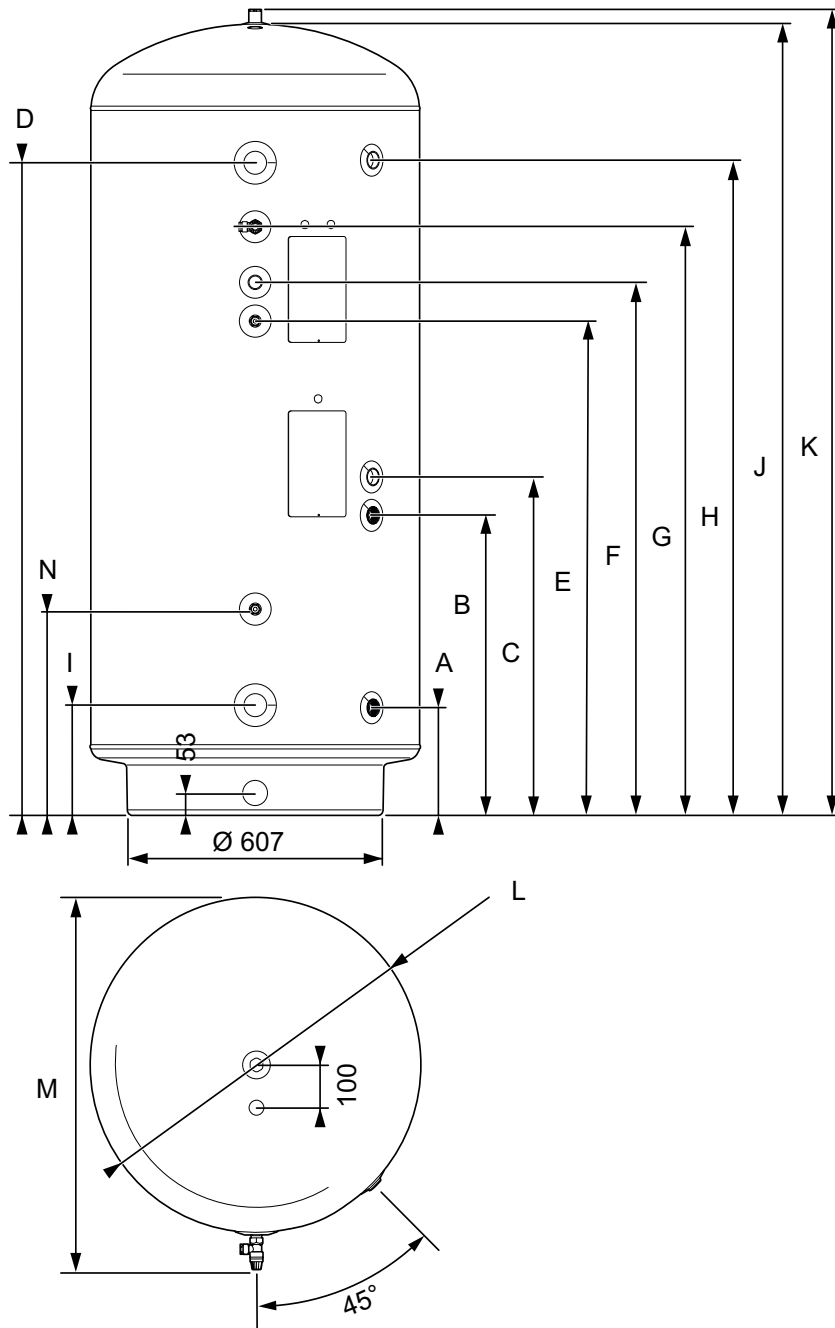

Heat pump cylinder	Unit	A	B	C	D	E	F	G	H	I	J	K	L	M	N
500 litre auroSTOR	mm	252	703	793	1,529	1,158	1,249	1,379	1,529	259	1,853	1,886	785	872	484

Connections

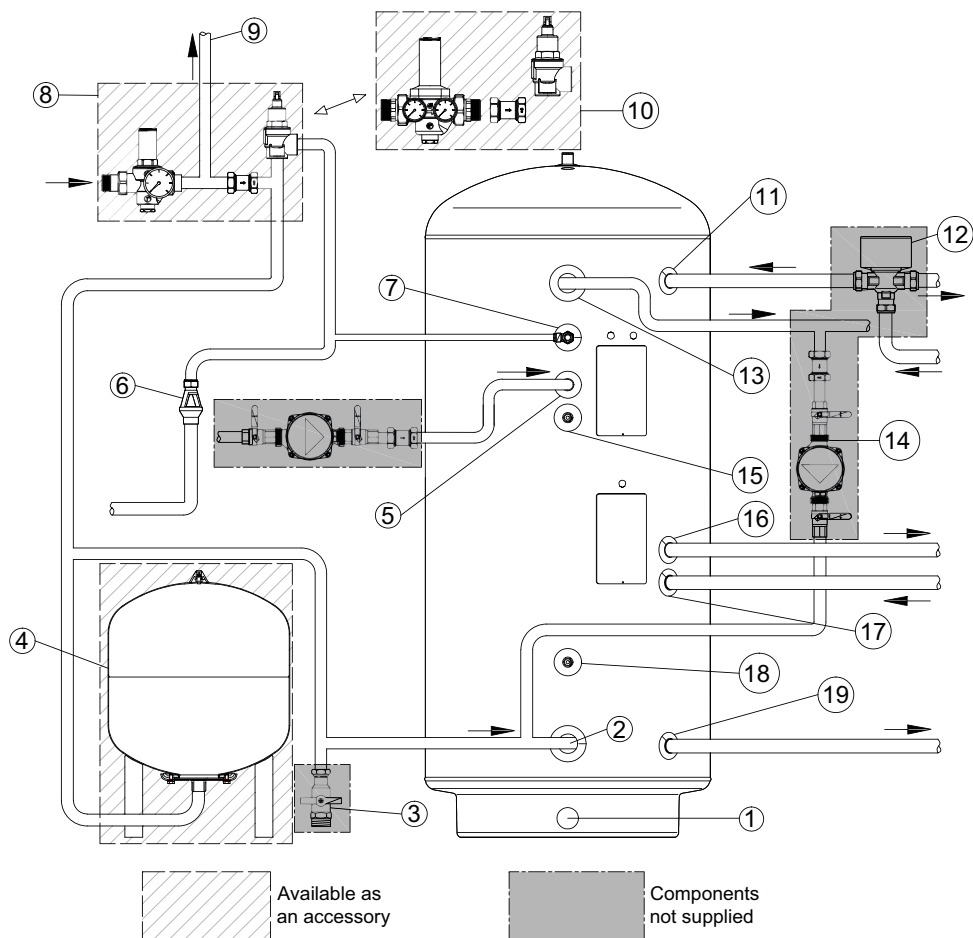

Item	Description
1	Cylinder drain
2	Cold water inlet
3	System drain valve (not supplied)
4	Expansion vessel (available as an accessory)
5	Secondary circulation (not supplied)
6	Tundish
7	Temperature-pressure relief valve
8	Unvented cylinder kit (available as an accessory)
9	Balanced cold water
10	2" unvented cylinder kit supplied with additional pressure gauge (available as an accessory)
11	Cylinder heating flow
12	Three-way motorised diverter valve (not supplied)
13	Hot water outlet
14	Legionella protection loop (not supplied)
15	Temperature sensor pocket
16	Cylinder heating return
17	Cylinder solar inlet
18	Solar temperature sensor pocket
19	Cylinder solar return

NOTE: Items included with large capacity auroSTOR cylinders are documentation and tundish. Unvented cylinder kits and expansion vessels are available in a range of sizes as an accessory, see page 26.

uniSTOR and auroSTOR accessories

Description	Article number
Immersion heater 7kW (800 litre uniSTOR only)	0020235671
Unvented cylinder kit 1"	0020235964
Unvented cylinder kit 1¼"	0020235965
Unvented cylinder kit 1½"	0020235966
Unvented cylinder kit 2"	0020235967
Expansion vessel 50 litre (for uniSTOR and auroSTOR 500 litre)	0020229941
Expansion vessel 80 litre (for uniSTOR 800 litre)	0020229942

Expansion vessel dimensions

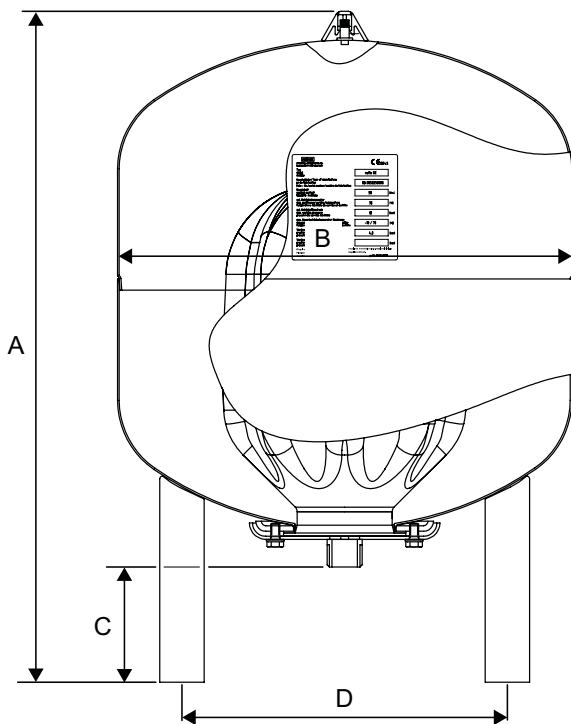

Dimensions	Unit	50 litre expansion vessel	80 litre expansion vessel
A = Height	mm	604	729
B = Diameter		409	480
C = Connection height		104	152
D = Feet span c/c		293	351

Pressure drop chart

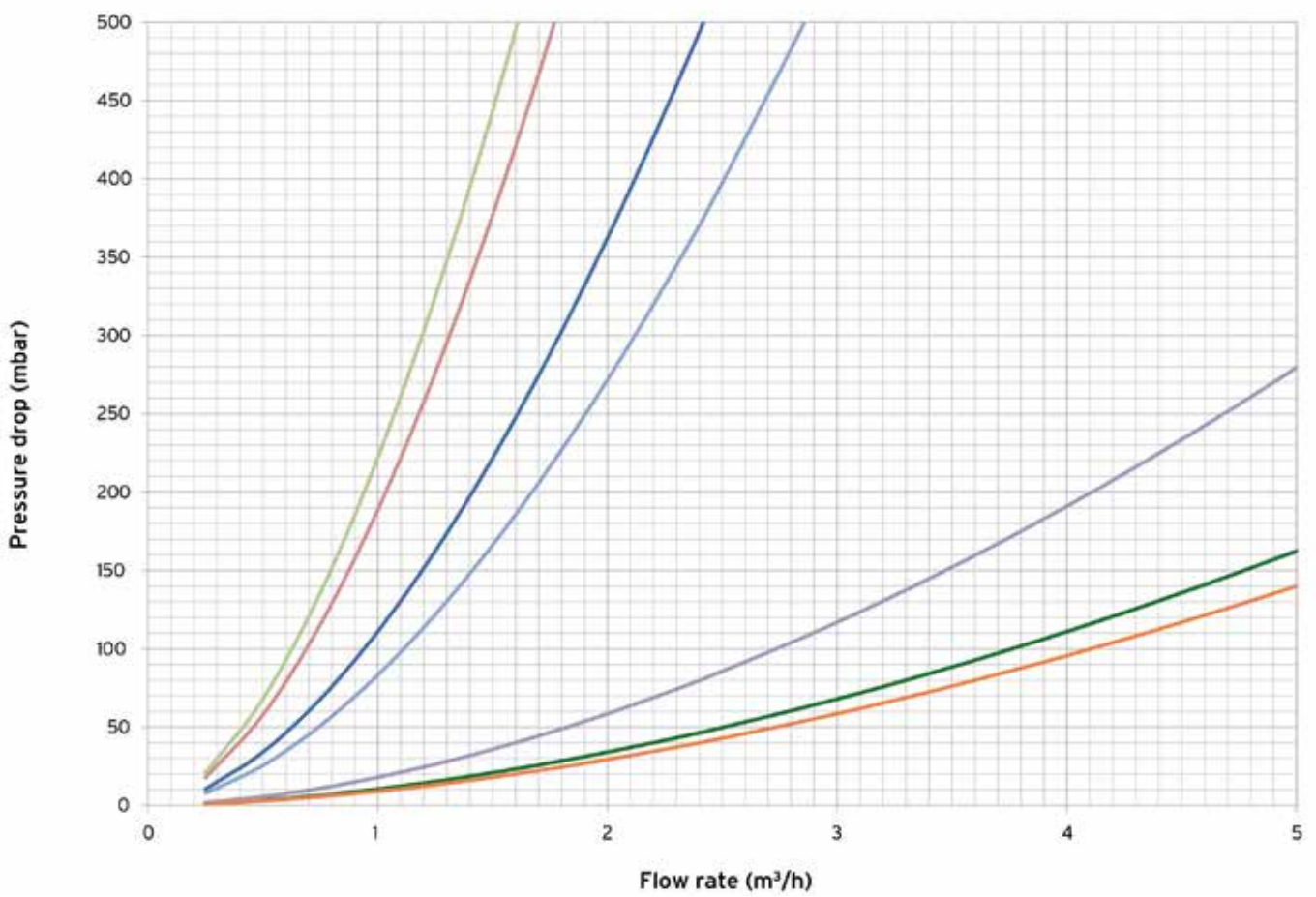

— 1.0 m² (Ø22 mm) = uniSTOR 150 litre and auroSTOR 500 litre (lower coil)

— 1.4 m² (Ø22 mm) = uniSTOR 200 litre

— 2.4 m² (Ø22 mm) = uniSTOR 250 litre

— 2.8 m² (Ø22 mm) = uniSTOR 300 litre

— 2.3 m² (Ø35 mm) = auroSTOR 500 litre (upper coil)

— 4.7 m² (Ø25.4 mm) = uniSTOR 500 litre

— 7.0 m² (Ø25.4 mm) = uniSTOR 800 litre

Customer service and support

contact details.

Sales Support

Vaillant products are available to purchase from reputable heating merchants in the UK. To find contact details for your nearest Vaillant representative:

Telephone: 0345 602 0262

General Enquiries

If you have a general enquiry our friendly reception staff will happily point you in the right direction:

Telephone: 0345 602 2922

Commercial Service

For commercial products aftersales service and commissioning:

Telephone: 0207 022 0927

Email: commercial@vaillant.co.uk

Renewable Service

For renewable products aftersales servicing and commissioning:

Telephone: 0330 100 3540

Email: aftersales@vaillant.co.uk

Commercial Technical Enquiries

For technical assistance:

Telephone: 0330 102 8570

Email: technical@vaillant.co.uk

Renewable Technical Enquiries

For renewable technical assistance:

Telephone: 0330 100 3540

Email: aftersales@vaillant.co.uk

Training Enquiries

Vaillant provide many different training courses. For more information:

Telephone: 0345 601 8885

Email: training.enquiries.uk@vaillant-group.com

Vaillant Group UK Ltd

Nottingham Road, Belper, Derbyshire DE56 1JT

Telephone: 0345 602 2922 ■ **www.vaillant.co.uk** ■ **info@vaillant.co.uk**

